

Technical Specifications

Pressure measuring range (bar)

	0.1 ... 0.5, (1)	> 0.5 ... 2	> 2 ... 25
Overpressure	3 bar	3 x FS (≥ 3 bar)	3 x FS
Burst pressure	> 200 bar	> 200 bar	> 200 bar
Accuracy, (5), (\pm % FS)	$\leq 0.5 / \leq 0.25$	$\leq 0.5 / \leq 0.25 / \leq 0.1$	$\leq 0.5 / \leq 0.25 / \leq 0.1$
Thermal shift, (\pm % FS/$^{\circ}$C)			
Zero point 0...70 $^{\circ}$ C	≤ 0.06	≤ 0.03	≤ 0.015
Zero point -25...85 $^{\circ}$ C	≤ 0.08	≤ 0.04	≤ 0.02
Span 0...70 $^{\circ}$ C	≤ 0.015	≤ 0.015	≤ 0.015
Span -25...85 $^{\circ}$ C	≤ 0.02	≤ 0.02	≤ 0.02
Response time, (typ.)	< 1ms / 10...90% FS	< 1ms / 10...90% FS	< 1ms / 10...90% FS
Long term stability, (6)	< 0.5% FS / < 4 mbar	< 0.2% FS / < 4 mbar	< 0.1% FS / < 0.2% FS

	> 25 ... 600, (2), (3), (4)	> 600 ... 1000, (2)
Overpressure	3 x FS ($\leq 850 / \leq 1500$ bar)	1500 bar
Burst pressure	> 850 / ≤ 1500 bar	> 1500 bar
Accuracy, (5), (\pm % FS)	$\leq 0.5 / \leq 0.25 / \leq 0.1$	$\leq 1 / \leq 0.5 / \leq 0.25$
Thermal shift, (\pm % FS/$^{\circ}$C)		
Zero point 0...70 $^{\circ}$ C	≤ 0.015	≤ 0.015
Zero point -25...85 $^{\circ}$ C	≤ 0.02	≤ 0.02
Span 0...70 $^{\circ}$ C	≤ 0.015	≤ 0.015
Span -25...85 $^{\circ}$ C	≤ 0.02	≤ 0.02
Response time, (typ.)	< 1ms / 10...90% FS	< 1ms / 10...90% FS
Long term stability, (6)	< 0.1% FS / < 0.2% FS	< 0.1% FS / < 0.2% FS

(1) 50 mbar on request

(2) Titanium available ≤ 400 bar (burst pressure > 550 bar)

(3) Process connection frontal and flush diaphragm available ≤ 600 bar

(4) Overpressure and burst pressure 1500 bar (stainless steel) optional

(5) Zero based accuracy according to DIN16086, incl. hysteresis and repeatability at ambient temperature

(6) 1 year (typ. / max.), the long term stability can be improved by ageing (burn-in) the sensor

Temperature range

Operating temperature	-25...85 $^{\circ}$ C
Process temperatur	-40...150 $^{\circ}$ C
Storage temperatur	-25...85 $^{\circ}$ C

Electrical specifications

	4 ... 20 mA	0 ... 20 mA	0 ... 5 V / 0 ... 10 V
Power supply	9...33 V DC	9...33 V DC	15...30 V DC
Supply influence	< 0.1% FS	< 0.1% FS	< 0.1% FS
Current consumption			3 mA
Circuit diagram			
Load resistance			$R_L > 10k\Omega$
Load influence	< 0.1% FS	< 0.1% FS	< 0.1% FS

Qualifications

	Description	Level	Typical interferences
EN 61000-4-2	Electrostatic discharge	4 kV contact 8 kV air	
EN 61000-4-3	Irradiated RF	10V/m (0.08...1 GHz)	Radio sets, wireless phones
EN 61000-4-4	Transients (burst)	2 kV	Motors, valves
EN 61000-4-5	Surge	10 kA (8 / 20 μ s), (1)	Lightning
EN 61000-4-6	Conducted RF	10 V (0.15...80 MHz)	Frequency converters

(1) Only with optional surge (lightning) protection

Physical specifications

Materials	
Transducer	Stainless steel (316L / 1.4435), titanium (Gr. 2), (1)
Housing	Stainless steel (316L / 1.4404), titanium (Gr. 2)
Seals	Viton (Standard), EPDM, Kalrez
Cable	PUR, FEP, PE

(1) Hastelloy (C-276) on request

Accessories

Cable socket connector

HART001	Cable Socket Connector
HART002	Cable socket connector, Binder 723, IP67, 5-pins
HART006	RSF50, IP67, 2m, angled, for absolute and sealed gauge
HART009	Binder 723, IP 67, 12-pins
HART012	MIL C26482, 10-6, IP40, 6-pins
HART018	Lumberg, RSF 4/5, 5-pins
HART026	Binder 723, IP67, 7-pins
HART049	
HART058	Cable socket connector, DIN 43650, micro

Overview

10.00.0091	Accessories overview

Additional documents

Operating and safety instructions

	Article number
10.88.0092	DMM029

Ordering information

		X. XXXX.	XXXX.	XX.	XXX
Type					
	ATM	23			
Pressure type					
	Gauge	1			
	Absolute (vacuum)	2			
	Sealed gauge	3			
Pressure measuring range					
	50 mbar...< 100 mbar	XX			
	100 mbar... 600 bar	XX			
	> 600 bar	XX			
	Negative ranges, offset, special adjustment	99			
Process connection					
	G 1/4 F (Fig. 1)	00			
	1/4 NPT M	10			
	1/2 NPT M, (Fig. 8)	19			
	G 1/4 M (Fig. 2)	11			
	G 1/4 flush diaphragm	21			
	G 1/4 A, Manometer DIN 16288 (Fig. 3)	12			
	G 1/2 M, (Fig. 3)	13			
	G 1/2 M, Hastelloy C-276	98			
	G 1/2 M, frontal diaphragm (Fig. 5), (4)	14			
	G 1/2 M, frontal diaphragm Hastelloy C-276	37			
	G 1/2 M, flush diaphragm (Fig. 6), (4)	15			
	G 1/2 M, Manometer DIN 16288, (Fig. 7)	16			
	G 1/2M with bore Ø 14 mm	17			
	Customized connection available	99			
Electrical connection					
	DIN 43650, demountable, IP 65 (Fig. 10), (5)		01		
	DIN43650 plastic PA, with metal threaded part, demountable		66		
	Binder 723, 5-pin, IP 67, (Fig. 11), (5)		03		
	Binder 723, 5-pin, demountable, IP 67, (Fig. 12), (5)		43		
	MIL C26482, 10-6, IP 40, (Fig. 13), (5)		06		
	Connector Lumberg RSF4, 4-pins		07		
	PE cable, IP 67, black (Fig. 14), (6), (8)		13		
	PUR cable, IP 67, black (Fig. 14), (6)		15		
	PUR cable, black, with submersible back end IP 68		24		
	FEP cable, black		21		
	Customized connection available		99		
Output signal					
	4...20 mA		05		
	0...20 mA		00		
	0...5 VDC		46		
	0...10 VDC		47		
	4...20 mA with surge protection		08		
	0...10 VDC with surge protection		49		
	0...5 VDC with surge protection		50		
	Customized connection available		99		
Accuracy					
	≤ 600 bar ≤ ± 0.5 % FS			0	
	≤ 600 bar ≤ ± 0.25 % FS			1	
	≤ ± 0.1 % FS			2	

	> 600 bar $\leq \pm 1$ % FS			5	
	> 600 bar $\leq \pm 0.5$ % FS			0	
	> 600 bar $\leq \pm 0.25$ % FS			1	
Temperature range					
	0...70 °C compensated (allowed process temperature: -25...100 °C)			0	
	25...100 °C compensated (allowed process temperature: -25...100°C)			7	
	-25...85 °C compensated (allowed process temperature: -25...100 °C)			1	
	-25...85 °C compensated (allowed process temperature: -25...150 °C) with cooling fins			2	
	20...100 °C compensated (allowed process temperature: -25...150 °C) with cooling fins			6	
	Customized connection available			9	
Option 1					
	Throttle, (9)				A
	Special oil filling: Anderol Food (for food applications)				G
	Special oil filling: Halocarbon (for oxygen applications), (10), (12), (13)				H
	Special oil filling: AS 100				J
	Special oil filling: PAO4 (silicone free)				Q
	Pressure connection elastomerfree				N
	Pressure connection welded				V
Option 2					
	Electronics packed in gel: Gauge pressure				C
	Electronics packed in gel: Absolute pressure				D
Option 3					
	Version titanium				K
	Seals: Viton (standard)				U
	Seals: EPDM				S
	Seals: Kalrez (Industry)				T
	Seals: NBR (ACS)				H
	TD with 100 mm diaphragm (for hydrogen applications, Pn > 25 bar)				Z

- (1) 50 mbar on request, negative pressure ranges on request
- (2) Titanium available ≤ 400 bar (burst pressure > 550 bar)
- (3) mbar, PSI, kPa etc. available
- (4) Process connection available ≤ 600 bar
- (5) Cable socket connector not included
- (6) Please specify the required cable length and medium
- (7) Suitable for drinking water (food approved)
- (8) For operating temperature > 50°C, PE or FEP cable must be used
- (9) Only with pressure connection Fig. 2, Fig. 3, Fig. 4, Fig. 7 and Fig. 8
- (10) Maximum pressure measuring range ≤ 270 bar (burst pressure > 400 bar)
- (11) ACS Certification
- (12) min. Medium temperature -25 ° C
- (13) Standard, no special cleaning. Special cleaning must be requested.

Technical drawings

Pressure Connections

Dimensions

Electrical Connections

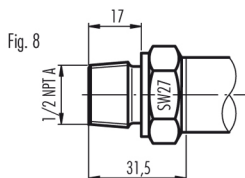
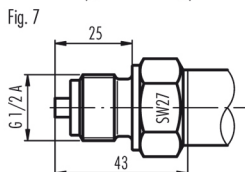
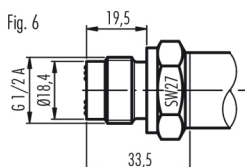
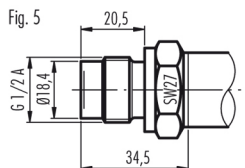
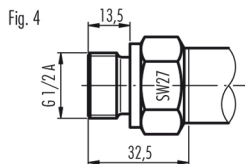
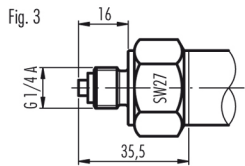
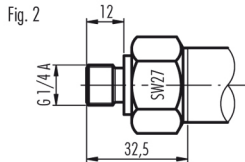
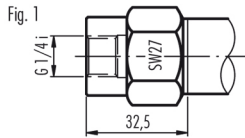

Version for medium temperature up to 100°C

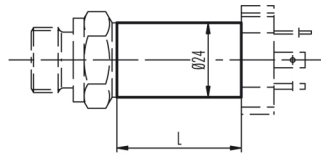

L = 40 mm for connector DIN 43650 (Fig. 10)
L = 94 mm for version with surge (lightning) protection
L = 45 mm for all other versions

Version for medium temperature >100°C up to 150°C

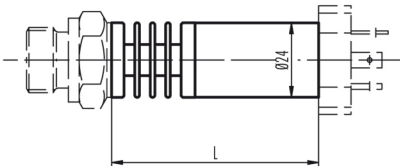

L = 67 mm for connector DIN 43650 (Fig. 10)
L = 121 mm for version with surge (lightning) protection
L = 72 mm for all other versions

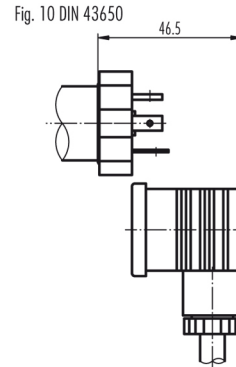

Pin	2-Wire	3-Wire
1	+Vin	+Vin
2	Pout	Pout
3		GND

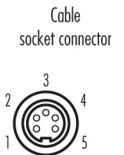
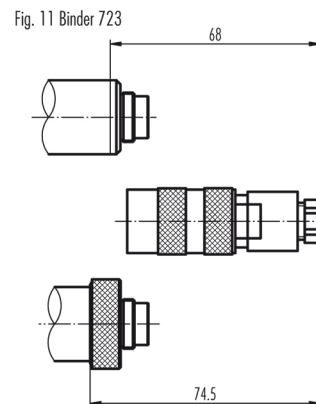
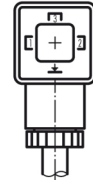

Pin	2-Wire	3-Wire
1	Pout	Pout
3	+Vin	+Vin
4		GND

Fig. 12 Binder 723

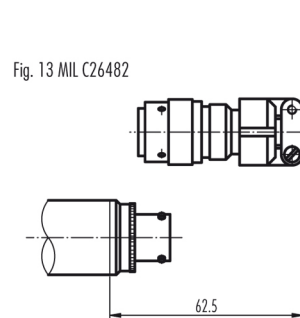

Pin	2-Wire	3-Wire
A	+Vin	+Vin
B		GND
C	Pout	Pout

Fig. 14 Cable

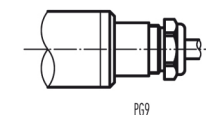

Colour	2-Wire	3-Wire
white	+Vin	+Vin
yellow	Pout	GND
brown		Pout

Specifications may change without notice.

STS Headquarters, Switzerland:
STS Sensor Technik Sirmach AG
Rüthofstrasse 8, 8370 Sirmach, Switzerland
sales@stssensors.com | www.stssensors.com

STS France:
STS France
844 Route de la Caille, 74350 Allonzier la Caille, France
info-fr@stssensors.com | www.stssensors.fr

STS Germany:
STS Sensoren Transmitter Systeme GmbH
Poststrasse 7, 71063 Sindelfingen, Germany
info-de@stssensors.com | www.stssensors.de

STS Great Britain:
STS Great Britain Ltd.
Box 3942 | Warwick | CV34 9AE, United Kingdom
contact@stssensors.com | www.stssensors.co.uk

STS Italy:
STS Italia s.r.l.
Via Gesù 5, 20090 Opera (Milano), Italy
info-italia@stssensors.com | www.stssensors.it